

# MURPHY®

## Steel Bed Frame - Model #SBF

Assembly Instructions

Stocked in:	Single/Twin	Single/Twin X-Long
	Double/Full	Double/Full X-Long
	Queen	King

One universal bed frame for each of Single, Double, or Queen wall beds.  
May be mounted in either vertical or horizontal modes.

A lightweight, universal, structural steel bed frame with double overlap steel stiffeners, completed with fold-away leg system. Designed to exceed the strength of wood or aluminum as well as residential and commercial specifications.

Designed to Exceed International ISO 9002  
Standards for residential specifications

**\*\*\* 15 YEAR WARRANTY \*\*\***

# Carton Contents for Steel Bed Frame (#SBF)

Note: Each carton contains one complete Single, Double, Queen or King Steel Bed Frame; complete with leg assembly and necessary hardware.

Stock#	Qty.	Item	Comments
1999E	2	Frame End Sections	Identical Head & Foot <input type="checkbox"/>
1999S	2	Frame Side Sections	Identical Right or Left <input type="checkbox"/>
S456 (SK7)	3 (5)	Stiffeners - Bed Face (King Size)	Space evenly between Frame Sides <input type="checkbox"/>
LG-13	2	Fold-away Legs	One Left - One Right <input type="checkbox"/>
LR	1	Leg Connector Rod	Stabalizes and Eases Leg Operation <input type="checkbox"/>
<b>(Hardware Bag #3)</b>			
1214	14	Bolt 10-24 x 1/2" Black	Bolt Frame corners <input type="checkbox"/>
1213	2	Bolt 10-24 x 1 1/4" Black	Bolt Leg Stop Foot corners <input type="checkbox"/>
1218	16	Nut 10-24 x Black Nylock	Use with #1214 & #1213 <input type="checkbox"/>
1226	4	Angle 1"x1"x1 3/4" Black	Use inside Frame corners <input type="checkbox"/>
1223	2	1/2" x 3/4" Round Black Cylinder	Use with #1213 as Leg Stop <input type="checkbox"/>
<b>(Hardware Bag #4)</b>			
1220	2	1 1/2" x 5/16" Black Washer	Secure Leg inside Frame <input type="checkbox"/>
1222	2	1 1/2" x .765" Black Washer	Secure Leg inside Frame <input type="checkbox"/>
1221	2	1 1/2" x .765" Black Nylon Washer	Between Leg & outside of Frame <input type="checkbox"/>
1217	2	Nut 5/16" Black Nylock	Secure Leg inside Frame <input type="checkbox"/>
1210	2	Bolt 1/4"-20 Black Hex Head	Attach Leg to Leg Rod <input type="checkbox"/>
SW1	2	Star Washer for #1210	Attach Leg to Leg Rod <input type="checkbox"/>
<b>(Hardware Bag #5)</b>			
1228	1	Nylon Web Strap with Buckle	Secure Mattress to Bed Frame <input type="checkbox"/>
1229	2	3/4" x 1/4" Washer	Secure Nylon Web Strap to Bed Face Panel under Mattress <input type="checkbox"/>
1224	2	#8 x 5/8" Wood Screw	Secure Nylon Web Strap <input type="checkbox"/>
<b>(Hardware Bag #7 - King size includes 2 bags)</b>			
1224	110	#8 x 5/8" Wood Screw	Attach Steel Bed Frame to Bed Face <input type="checkbox"/>
<b>(Hardware Bag #22)</b>			
1226	20	1" x 1" x 1 3/4" Black Corner Angle	Assemble Cabinets <input type="checkbox"/>
PS-1	2	1" x 3" Black Panel Saver	Assemble per Drawing <input type="checkbox"/>
	80	#8 x 5/8" Black Wood Screw	Attach the above <input type="checkbox"/>

## Steel Bed Frame (#SBF) Project Start-Up

- Familiarize yourself with all of the components in the Steel Bed Frame and mechanism cartons, as well as thoroughly study this manual so you may plan the steps required to complete this project.
- Study all illustrations and plan drawings. Make sure that the space available is adequate for the specified dimensions of the bed cabinet, both in the open and closed positions (see cut list pages to cross check dimensions).
- Panels should be 3/4" ply core. Particle board is acceptable but with more attention given to assembly procedures and handling. This is discussed further in this manual.
- Handles to pull the bed open are not provided. Select these from your local decorative hardware supplier. Have them on site at the time of assembly.
- Check to be sure that all items are available
  - Steel Bed Frame and Mechanism
  - Cabinet Components and Hardware
  - Necessary Tools

## Steps to Complete Project

1. Prepare all wood or laminate cabinet components.
2. Mount Lift Mechanism.
3. Install springs in Lift Mechanisms.
4. Assemble the Bed Cabinet.
5. Attach Bed Cabinet to wall.
6. Assemble Steel Bed Frame to Bed Face Panels.
7. Install the Bed Face Panel in Cabinet.
8. Install Handles, Leg Assembly, Mechanism Covers, Mattress

# Steel Bed Frame (#SBF) Component Layout

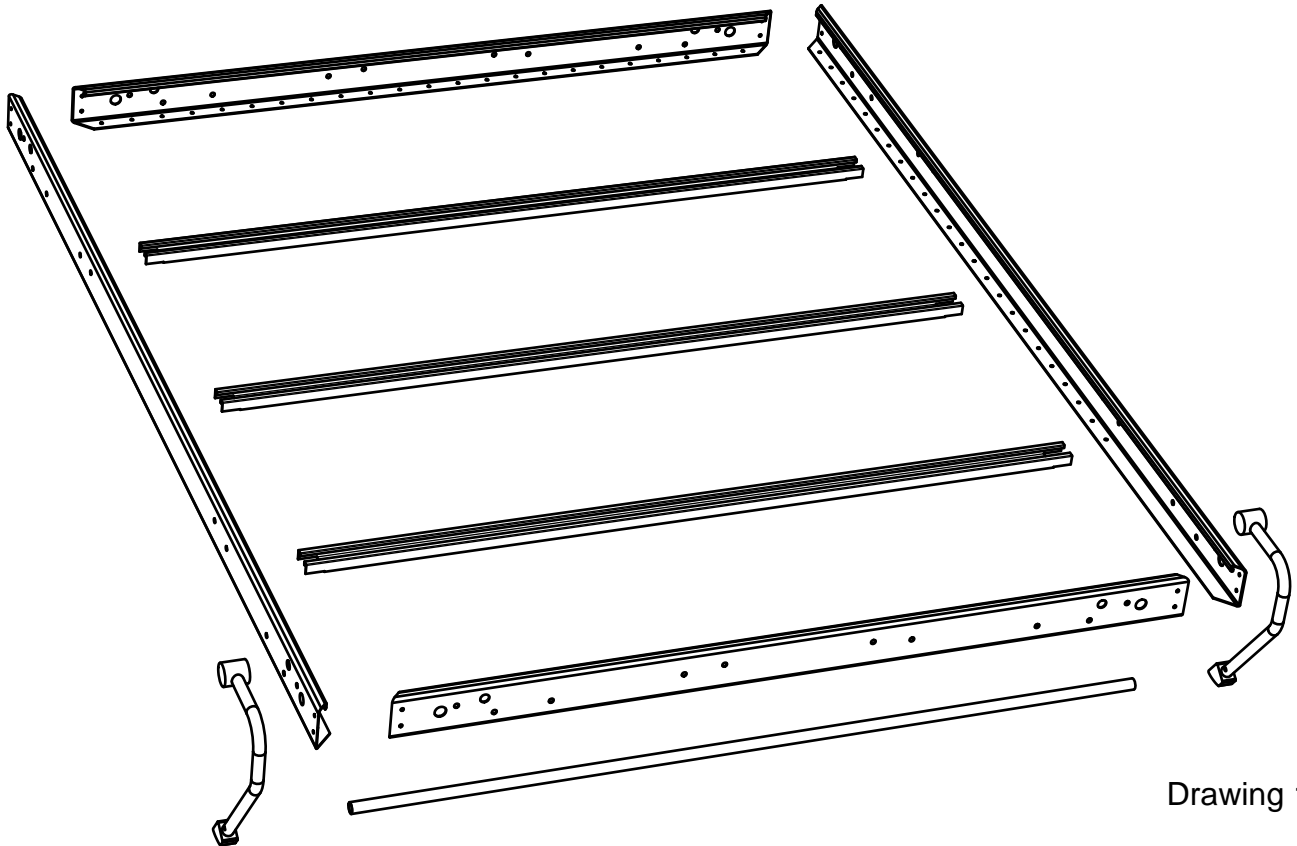

Drawing 1.

- Frame is adaptable as vertical or horizontal (side tilt) bed.
- Frame has mounting holes to use any of 4 Power Packs:  
SBLM - SBLMA - ACBM - GPLS

Photo Reference



# Steel Bed Frame (#SBF)- Vertical Bed Cabinet Cut List

## Cabinet for Power Packs: SBLM - SBLMA - GPLS

For use with 13" or 11" Leg Assemblies

Cabinets using 13" Legs use a 2" Facia and 4" Kick. See page 10 for details.

<b>Single / Twin Bed</b>		<b>Overall Cabinet Dimensions:</b> 44 1/2"w x 83 1/2"h x 16"d Protrusion from wall to foot bed: 84 1/2"		
<b>Mattress size:</b> 39" x 75" 12" max thickness		<b>Cabinet Material:</b> 3/4" MDF or Plycore		
Quantity	Description	Width	Length	Finish (Tape) Edges
2	Bed Face Panel	21 1/4"	77 5/16"	4 Edges
2	Side Panel	16"	83 1/2"	2 Long Edges
2	Headboard & Cabinet Top Panel	15"	43"	2 Long Edges
1	Cabinet Top Facia with 13" Leg or Bottom Kick with 11" Leg	2"	43"	2 Long Edges
1	Bottom Rear Base	6"	43"	2 Long Edges
1	Front Bottom Kick with 13" Leg or Top Facia with 11" Leg	4"	43"	2 Long Edges
<b>Double / Full Bed</b>		<b>Overall Cabinet Dimensions:</b> 59 1/2"w x 83 1/2"h x 16"d Protrusion from wall to foot bed: 84 1/2"		
<b>Mattress size:</b> 54" x 75" 12" max thickness		<b>Cabinet Material:</b> 3/4" MDF or Plycore		
Quantity	Description	Width	Length	Finish (Tape) Edges
4	Bed Face Panel	14 3/8"	77 5/16"	4 Edges
2	Side Panel	16"	83 1/2"	2 Long Edges
2	Headboard & Cabinet Top Panel	15"	58"	2 Long Edges
1	Cabinet Top Facia with 13" Leg or Bottom Kick with 11" Leg	2"	58"	2 Long Edges
1	Bottom Rear Base	6"	58"	2 Long Edges
1	Front Bottom Kick with 13" Leg or Top Facia with 11" Leg	4"	58"	2 Long Edges
<b>Queen Bed</b>		<b>Overall Cabinet Dimensions:</b> 65 1/2"w x 88 1/2"h x 16"d Protrusion from wall to foot bed: 89 1/2"		
<b>Mattress size:</b> 60" x 80" 12" max thickness		<b>Cabinet Material:</b> 3/4" MDF or Plycore		
Quantity	Description	Width	Length	Finish (Tape) Edges
4	Bed Face Panel	15 7/8"	82 5/16"	4 Edges
2	Side Panel	16"	88 1/2"	2 Long Edges
2	Headboard & Cabinet Top Panel	15"	64"	2 Long Edges
1	Cabinet Top Facia with 13" Leg or Bottom Kick with 11" Leg	2"	64"	2 Long Edges
1	Bottom Rear Base	6"	64"	2 Long Edges
1	Front Bottom Kick with 13" Leg or Top Facia with 11" Leg	4"	64"	2 Long Edges

# Steel Bed Frame (#SBF)- Horizontal Bed Cabinet Cut List

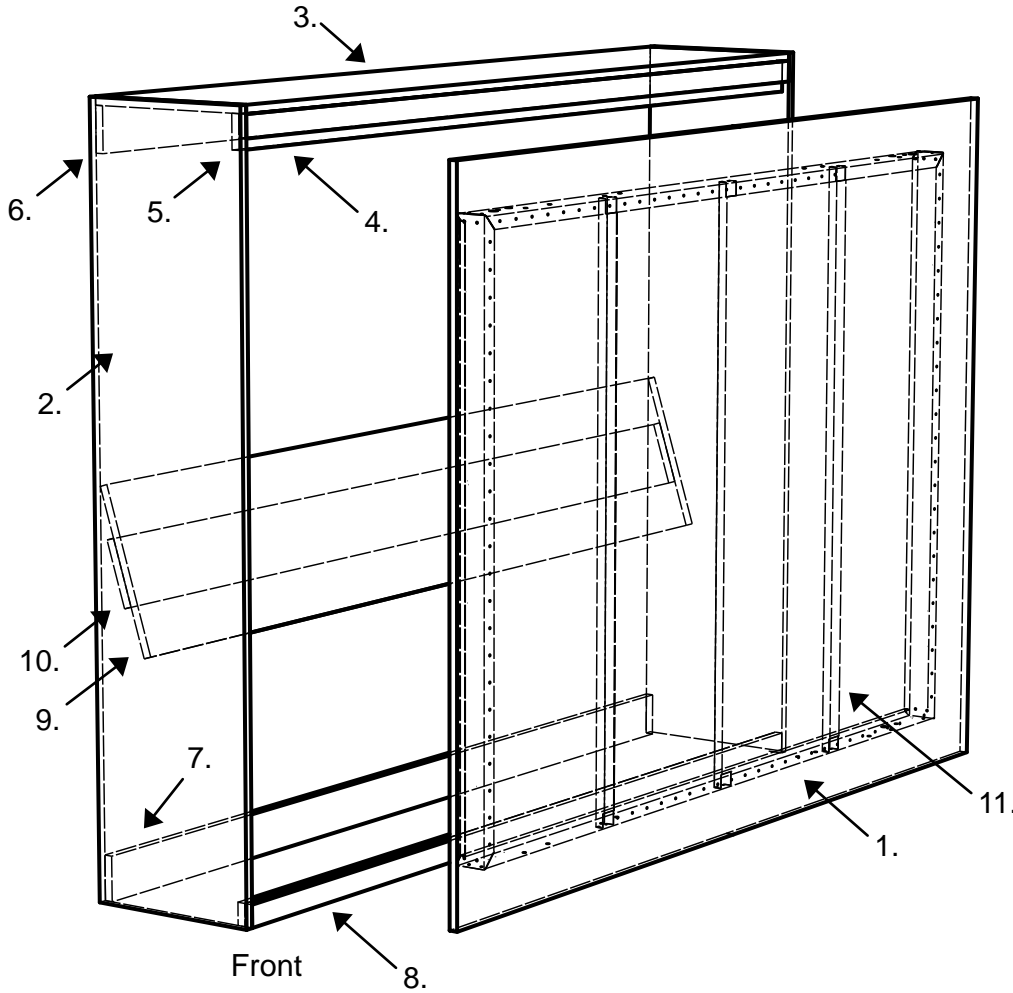

Drawing 2. Cabinet Profile

## For Power Packs:

#SBF:  
Steel Bed Frame

#SBLM:  
Spring Balance Lift Mechanism

#SBLM-A:  
Spring Balance Lift Mechanism Adjustable

#GPLS:  
Gas Piston Lift System

## Cabinet Components Description

1. Face Panels Edge band 4 sides
2. Side Panels Edge band 2 long
3. Top Stretcher Edge band 2 long
4. Front Facia Edge band 2 long
5. Front Facia Stiffener Edge band 2 long
6. Back Top Apron Edge band 2 long
7. Back Bottom Base Edge band 2 long
8. Kick & Kick Stiffener Edge band 2 long
9. Head Board Edge band 2 long
10. Head board Stiffener No edge hand
11. SBF Frame and Stiffeners

		Single / Twin Bed Double / Full Bed Queen Bed	Mattress size: 39" x 75" - 12" max thickness Mattress size: 54" x 75" - 12" max thickness Mattress size: 60" x 80" - 12" max thickness	Cabinet Material: 3/4" MDF or Plycore			
#	Qty	Description	Single	Double	Queen	Finish (Tape)	
1	2	Face Panel	39" x 41 3/4"	39" x 56 3/4"	41 1/2" x 62 1/2"	4 Edges	
2	2	Side Panel	16" x 47 3/4"	16" x 62 3/4"	16" x 68 3/4"	2 Long Edges	
3	2	Top Stretcher	16" x 78 1/2"	16" x 78 1/2"	16" x 83 1/2"	2 Long Edges	
4	1	Front Facia	2" x 78 1/2"	2" x 78 1/2"	2" x 83 1/2"	2 Long Edges	
5	1	Front Facia Stiffener	3" x 78 1/2"	3" x 78 1/2"	3" x 83 1/2"	2 Long Edges	
6	1	Back Top Apron	4" x 78 1/2"	4" x 78 1/2"	4" x 83 1/2"	2 Long Edges	
7	2	Back Bottom Base	4" x 78 1/2"	4" x 78 1/2"	4" x 83 1/2"	2 Long Edges	
8	2	Kick & Kick Stiffener	2" x 78 1/2"	2" x 78 1/2"	2" x 83 1/2"	2 Long Edges	
9	1	Head Board	15" x 78 1/2"	15" x 78 1/2"	15" x 83 1/2"	2 Long Edges	
10	1	Head Board Stiffener	6" x 78 1/2"	6" x 78 1/2"	6" x 83 1/2"	0 Edges	
11	3	Use 3 steel stiffeners provided with SBF. Mount vertically and evenly spaced.					



# Spring Application Chart

BED SIZE	BED PANEL MATERIAL	
	Plywood Core	Particle Board
Single/Twin	4-5 springs per side	5-6 springs per side
Double/Full	6-7 springs per side	7-8 springs per side
Queen	7-8 springs per side	8-9 springs per side
King	9 springs per side	not recommended

After you have completed installing and checking the operation of your bed, you may find it necessary to add or remove springs to achieve the correct lift effort of between 5 to 10 pounds.

There are nine locations for springs. If the bed requires an even number of springs, do not use the center hole (#5 from the top). If the bed requires an odd number of springs, start with the center hole (#5 from the top) and work outward in both directions evenly.

Hook the springs so the open ends are facing outward. You may have to gently pry up the tension arm and slide the spring under and snap them into place in the proper hole, matching the same numbered hole from the top of the mechanism back plate. You should have an equal number of springs on each side of the center hole.

Use the same number of springs and the same layout on both the left and right mechanisms.

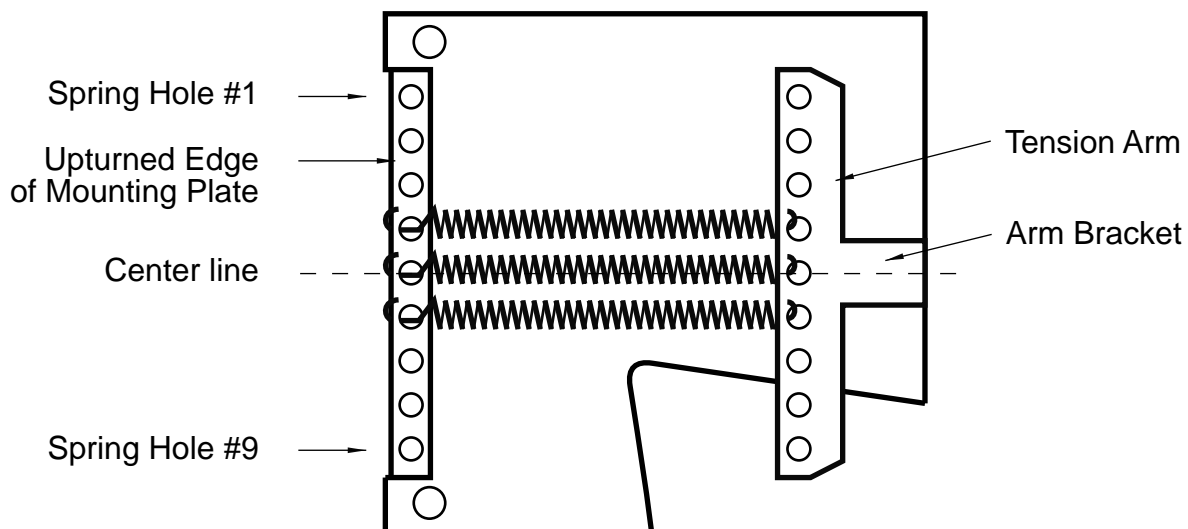

Drawing 5.

# Assembling the Bed Cabinet

- For easier final wall mount you should assemble bed cabinet in the room where it will be used.
  - Be sure Lift Mechanisms are securely installed.
1. Locate the mounting position of the headboard marking the left and right side panels 20" from the floor and 3" in from the back edge of the panels. Note from the plans #6 & #7 that this mounts the bottom edge of the headboard out 3" from the back or wall edge of the Side Panels. Use the 1" x 1" x 1 3/4" (2 each side) mounting brackets. Be sure the top bracket is set low enough not to protrude beyond the back of the cabinet. Use #8 x 3/4" Pan head Screws. The Headboard location may vary slightly; just be sure it is secure and at the approximate 3" angle from the back edge.
  2. Use Angle Brackets to assemble Bottom Stretcher and Kick in position shown in plan #6 & #7. Use two Angle Brackets on each end.
  3. Attach Top Stretcher as shown in plan #6 & #7. Be sure back edge of the Stretcher is flush with back of Side Panels and inset 1" from front of Side Panels, and 2" down from top of Side Panels to match the height of the Facia. Facia sits on top of Top Stretcher flush with front edge and flush with top end of Side Panels.

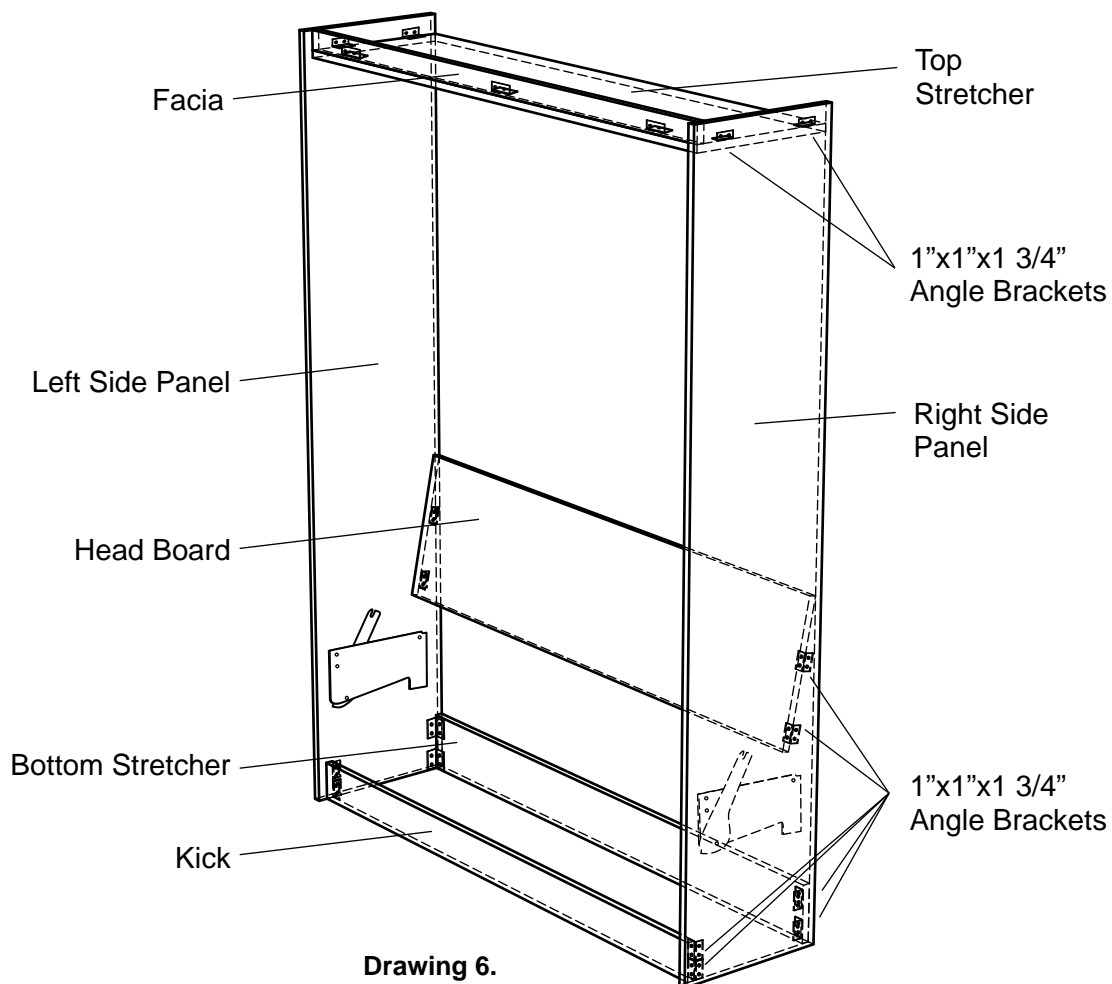

# Assembling the Bed Cabinet (cont.)

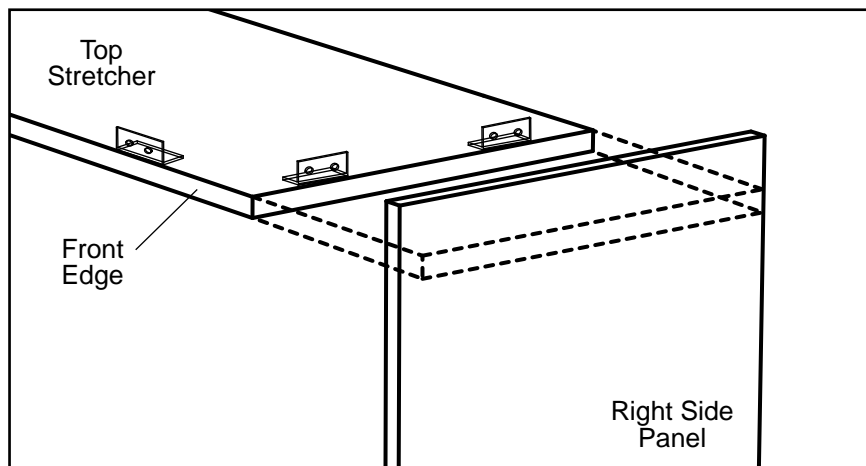

Drawing 8.

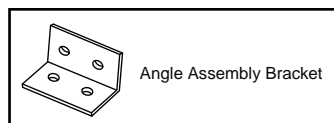

Angle Assembly Bracket

**NOTE:**  
 Facia and Kick cabinet parts are interchangeable for use with either the 11" Leg Assembly or the 13" Leg Assembly. Follow these directions:  
 When using the 11" Bed Leg Assembly, use the 2" tall board as the Kick and the 4" board as the Facia.  
 When using the 13" Bed Leg Assembly, use the 4" tall board as the Kick and the 2" board as the Facia.

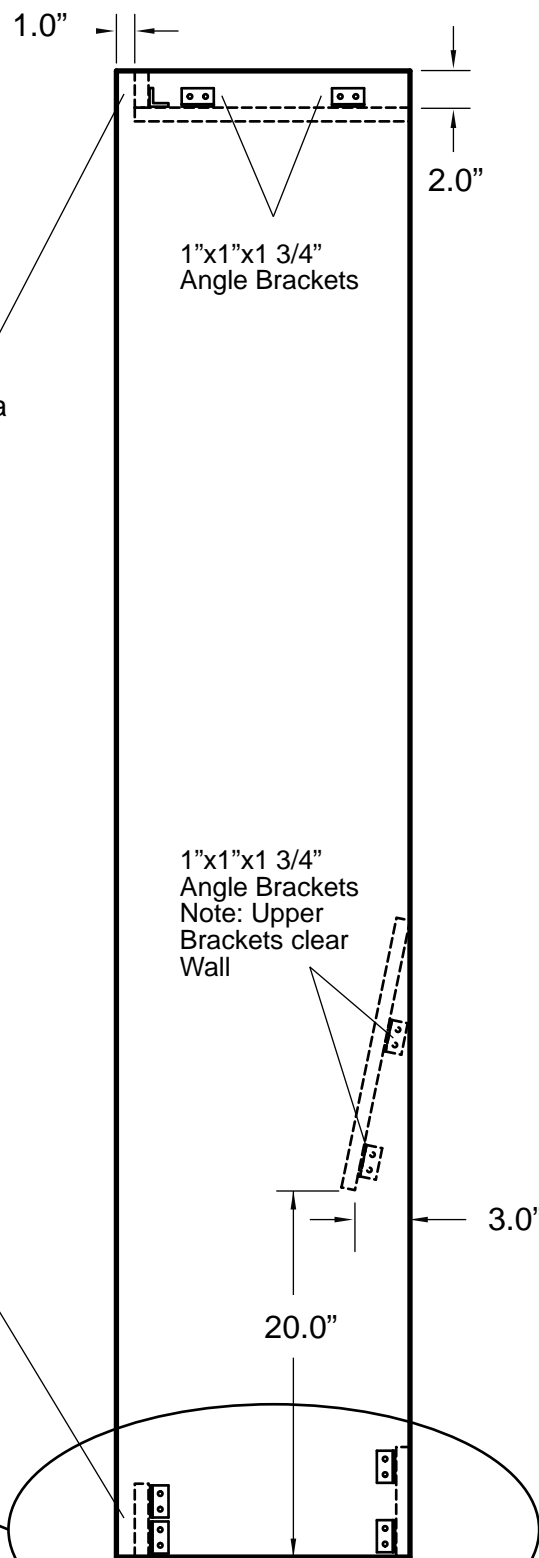

Drawing 7.

# Attach Bed Cabinet Securely to Wall

**Hints:** If the room is carpeted you may raise the kick up to 1/4" to clear the carpet. More than 1/4" will obstruct the operation of the bed.

- You may or may not wish to remove the Base Board to allow the Bed Cabinet to fit flush against the wall. If you do remove the Base Board, save for later trim and replacement. If you do not wish to remove the Base Board, you may use a shim or filler strip of the same thickness at the top between the cabinet and the wall.
1. Place cabinet against wall. Make sure the cabinet is level and square. Measure diagonally to be sure of square. Bed will not operate if cabinet is not square. Check also for square from front to back as well as side to side. Use shims where necessary.
  2. Prior to placing cabinet against the wall, locate 3 studs or other wall frame members at the level of the Top Stretcher panel (top of bed).  
**Alert:** The cabinet must be secured to studs or other wall structural members using 2" x 2" L-Brackets. If the wall is not a wood stud wall, use metal stud screws, toggle bolts or concrete expansion bolts if necessary.
  3. Now that the cabinet is square and plumb, use two #8 x 2" flat head wood screws in each of three 2" x 2" brackets to attach to studs at the top level of the Top Stretcher (see Drawing 9.). Re-check square and plumb and then secure 2" x 2" L-Brackets to Top Stretcher with #8 x 3/4" wood screws. Attach warning label to top of cabinet. Attach three Bumper Buttons to front edge of Top Stretcher. These Bumpers allow the Bed Face Panel to close quietly.

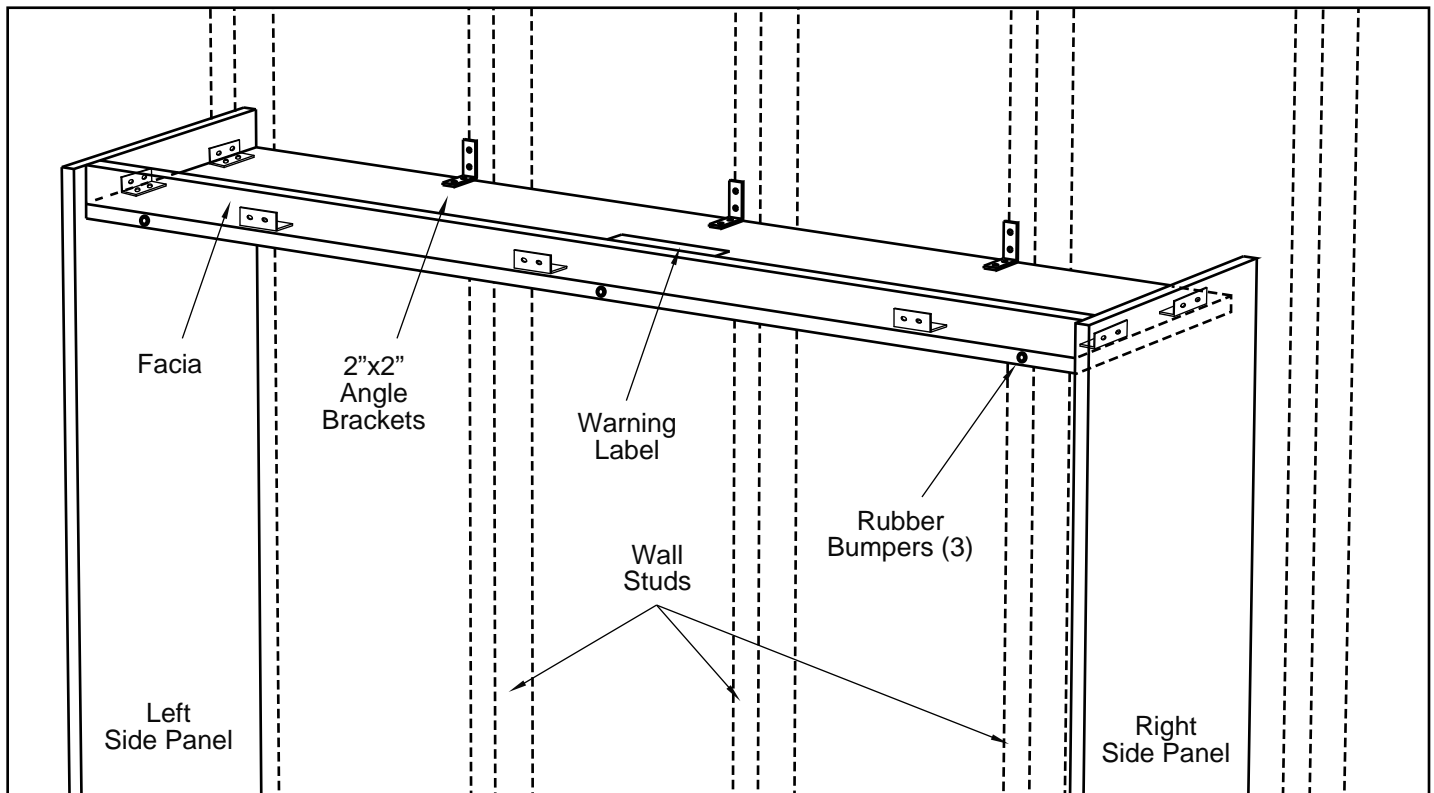

Drawing 9.

# Assemble Steel Bed Frame to Face Panels

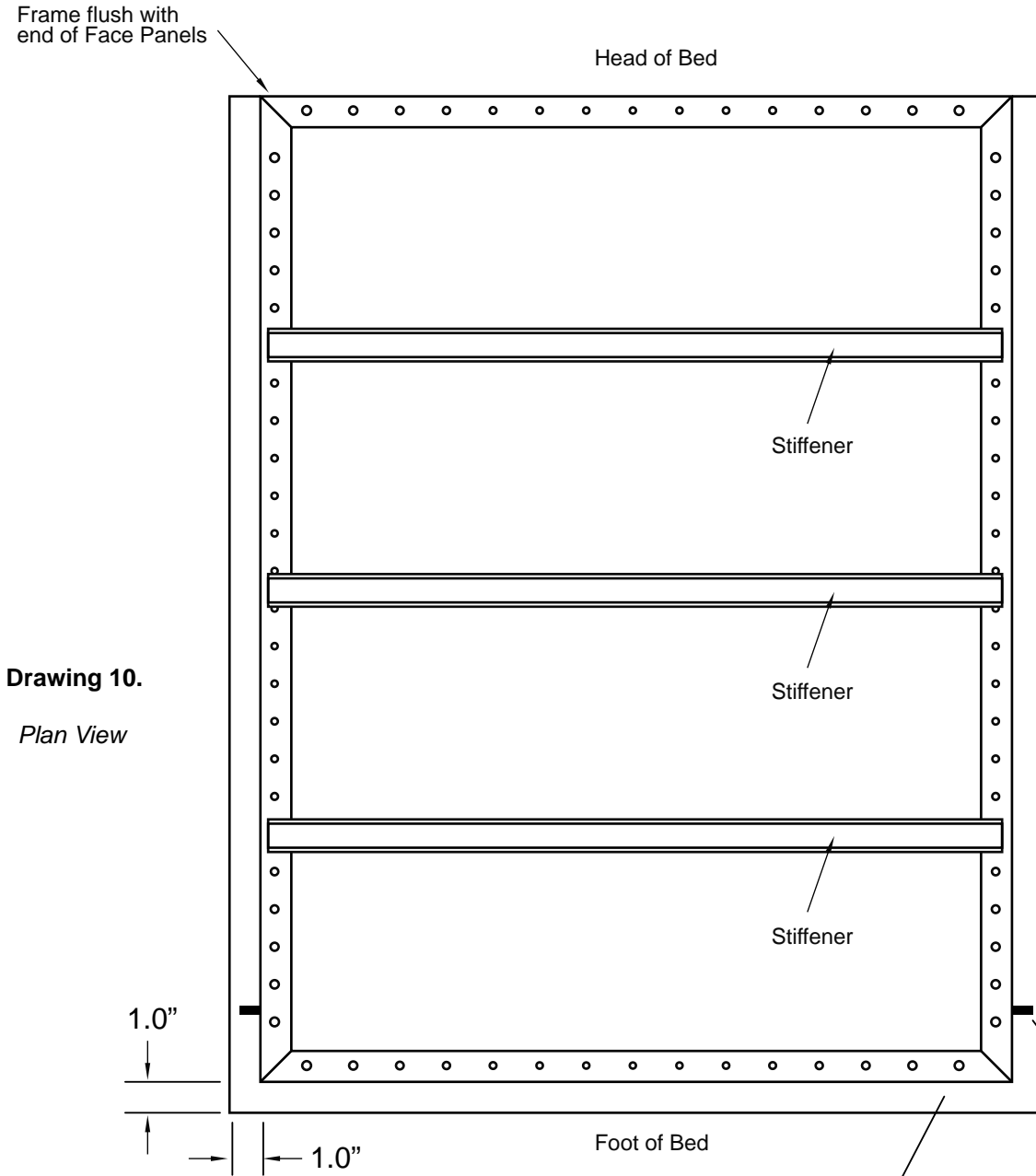

**Drawing 10.**  
*Plan View*

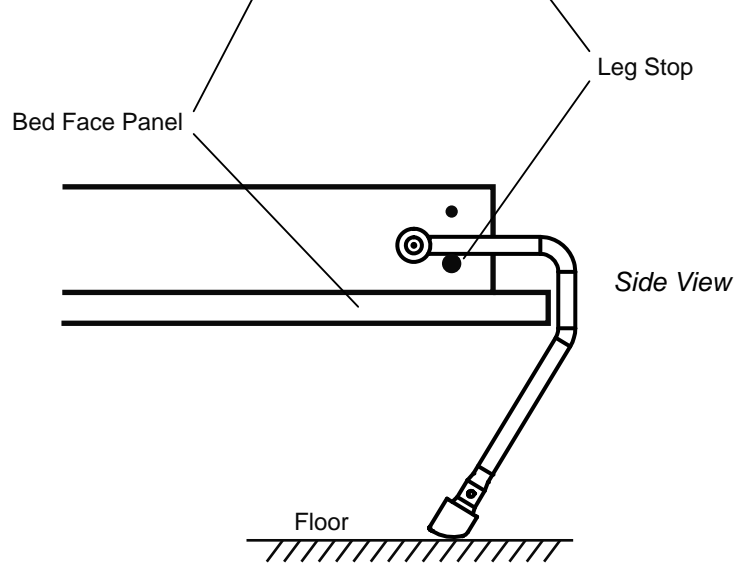
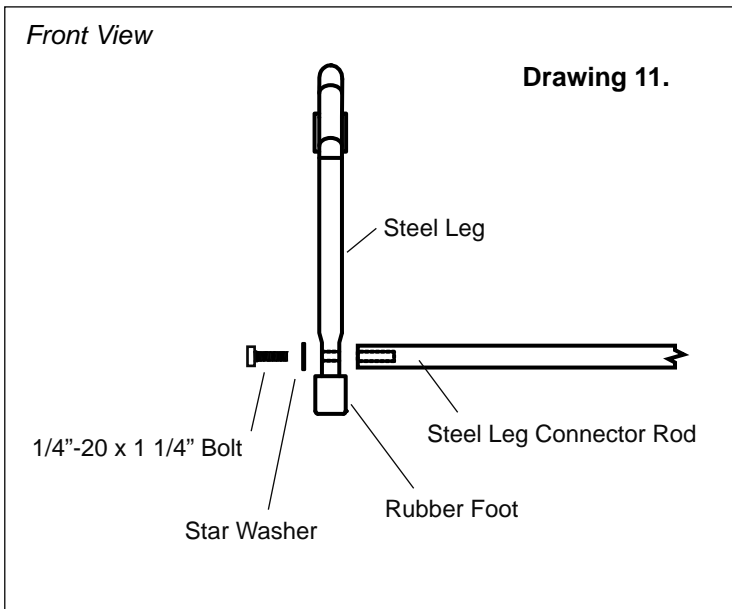

**Drawing 12.**

# Assemble the Bed Face Unit

## **Step 1:**

Lay the Bed Face Panels down on a non-scratch surface such as a carpet or blanket.

## **Step 2:**

Completely assemble the 4 Frame Sections with the corner brackets and the 3/16" x 1/2" black bolts provided. Refer to Drawing 12 to properly place the leg stops at outer right and left bottom holes at the foot of the bed frame.

## **Step 3:**

Position the bed frame on the bed face panels. With the Head Frame section flush with the head end of the Bed Face Panels. Refer to Drawing 10. Carefully attach the Bed Frame so it is centered on the Bed Face Panels; you will have approximately 15/16" space from the bed frame to the panel edges right and left and at the bed foot.

Note: It is very important to have the Bed Frame centered on the Bed Face Panels. Any error will be noticed in the vertical sight lines when the bed is closed.

## **Step 4:**

Three steel stiffeners are provided for all beds. These notched stiffeners should be located and attached to divide the Bed Face length into four equal sections. Use caution not to damage raised panels by putting screws in recessed areas.

## **Step 5:**

Attach the Nylon Web Strap approximately 18" from the foot of the bed. The Straps help secure the mattress in the vertical position.

## Setting the Lift Mechanism

Holding one foot against the bottom front edge of the side panel and using the 13" PVC tube, lever the tension arm out until you can set the arm lock to the hex nut at the hole A (see drawing 11.). This is the hex nut at the top front corner of the mechanism.

### Caution:

If possible have a helper assist in the setting of the mechanism and loading of the bed face panel. Do Not reach behind the tension arm when you are doing the setting procedure.

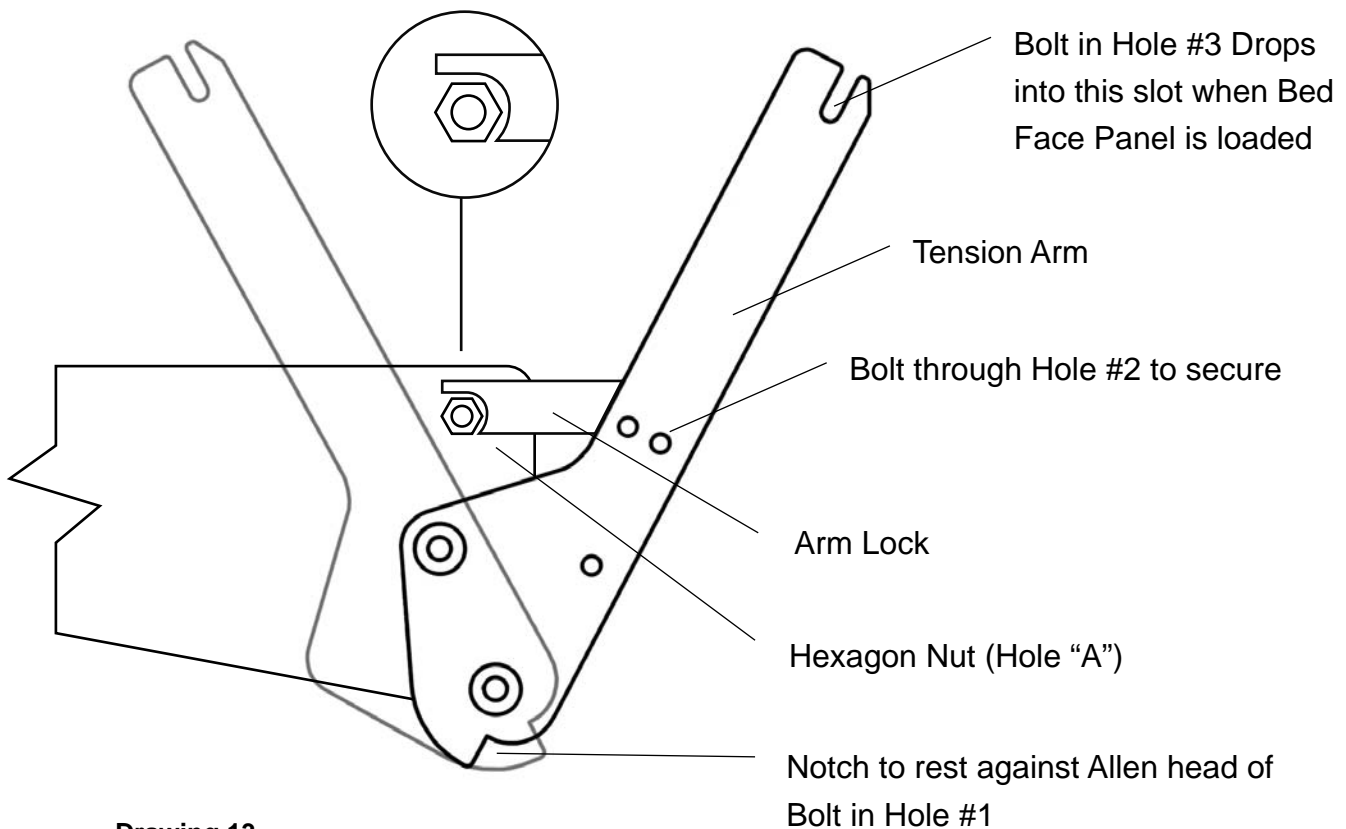

Drawing 13.

# Install the Bed Face Panel Unit

1. Insert the two Allen Head Bolts from the outside of the Frame through Hole #1 (see drawing 12) use 5/16" Nylock nuts and securely tighten. Stand the Bed Face Panel in vertical position between the tension arms, lift evenly until the bolt in Hole #3 drops in the notched end of each tension bar. Gently tilt the bed face toward you until the Allen Bolts in Hole #1 are completely seated in the bottom notch of the tension bar. Insert the remaining 5/16" x 3/4" Hed Head Bolts in Hole #2, tighten bolts #1 and #2 securely.
2. Insert two 5/16" x 3/4" Hed Head Bolts from the outside through Hole #3 (see drawing #4a) put 5/16" Nylock nuts on these bolts only until the nut is flush with the bolt end.

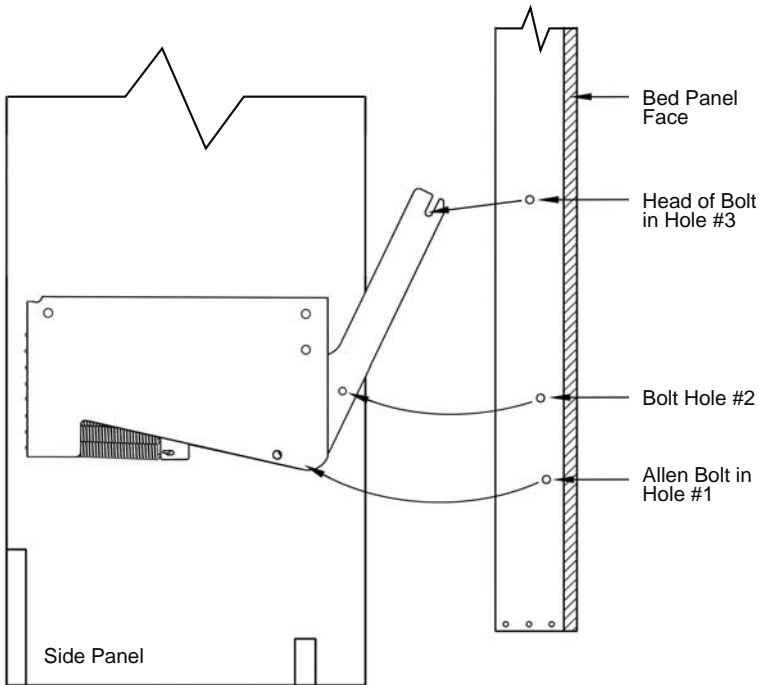

Drawing 14.

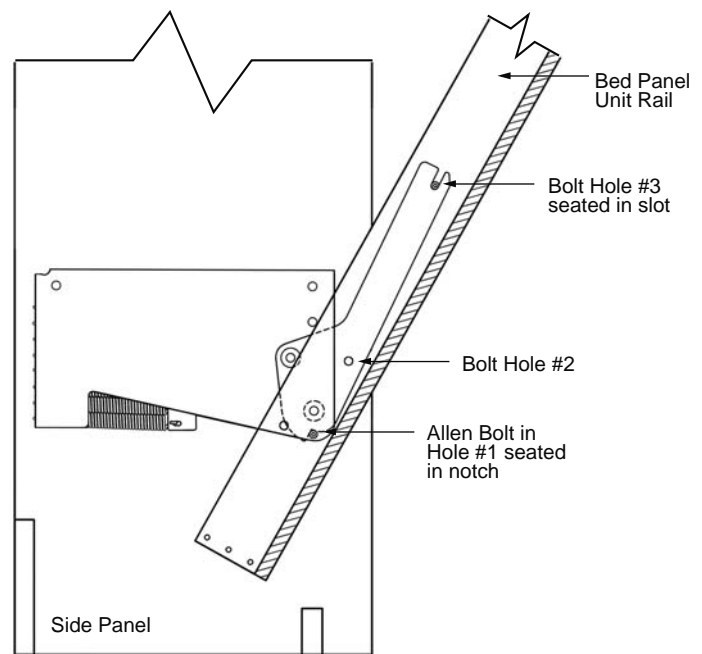

Drawing 15.

When all bolts are securely tightened, you may tilt the panel outward to approximately 45 degrees to release the arm locks. You will hear a click as they disengage.

## CAUTION:

Hold the Face Panel securely, Do Not let it slam shut. Balance is not achieved until the mattress is loaded in the bed.

Leveling of the bed cabinet is essential. Check the level both side to side and front to back. Proper leveling will facilitate proper closure and exact sight lines of the fit of the Face Panel to the Cabinet.

Load mattress onto the bBed Frame/Face Panel, secure the mattress with Nylon Web Straps provided.

## CAUTION:

If possible have a helper assist in the setting of the mechanism and loading of the Bed Face Panel. Do Not reach behind the tension arm when you are doing the setting procedure

# Install Handles, Legs, Mechanism Covers, & Mattress

1. Position and secure handles for ease of operation. Measure down approximately 36" from the panel top to the top of the handles.
2. Install legs with the washers on the inside of the Rails and the Nylon washer on the outside. Tighten nut to have a small amount of friction when leg assembly is rotated from the up to down position.

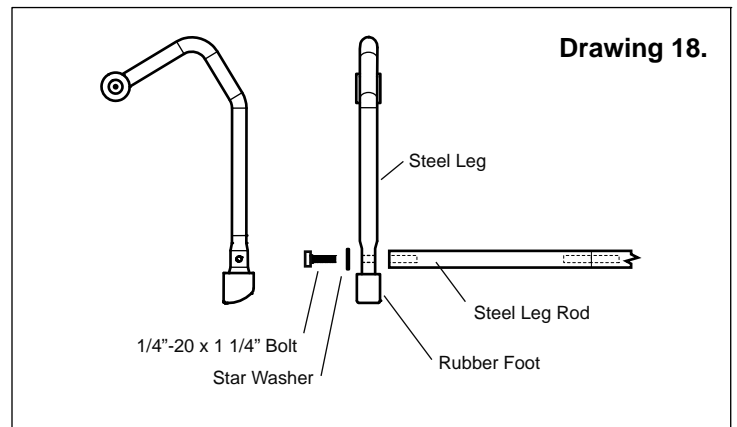
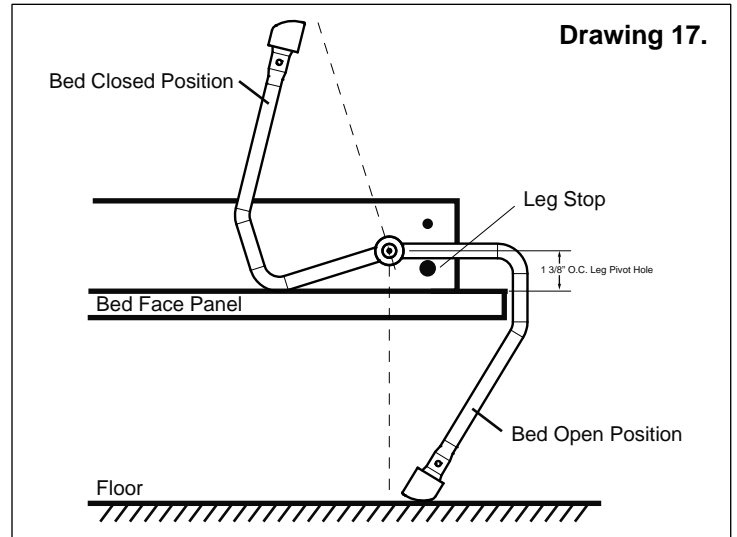
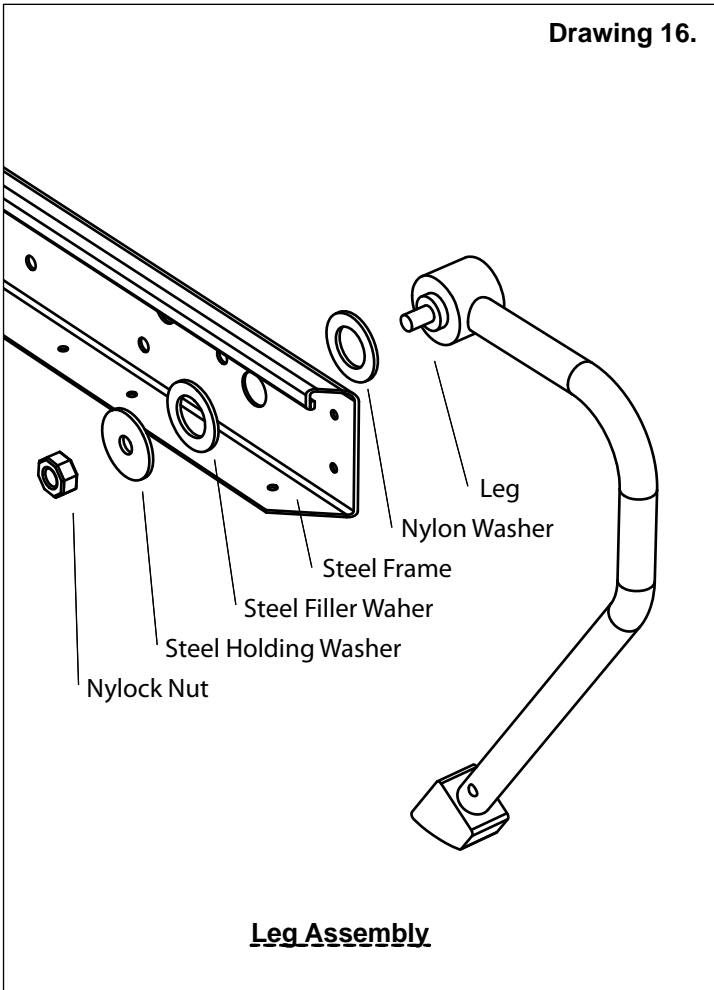

3. Install leg connector rod between legs and secure with 1/4" x 1 1/4" Hex head bolts and star washers. Be sure they are securely tightened so not to become loose.
4. Install mattress and secure with previously installed Nylon Straps.
5. Snap the powder coated steel mechanism covers in place - secure with #8 x 1 1/4" black wood screws through the standoff on the backer plate.

## **Follow up to Initial Assembly**

Level or square problems of Bed Face fit to Cabinet. Nudge base of Cabinet at the floor level - or do shims under the Side Panels. If bed is too heavy to operate easily or slams shut: remove Bed Face Panel and add or subtract springs. At this time you may decide to use one more or less spring(s) on the left or right side Lift Mechanism.